

Heart of the Design

The patented on-line suction side wear clearance adjustment permits the initial clearances to be maintained throughout the life of the pump. This extends the life of the impeller and suction wear faces to near, or equal that of, the casing for a one time maintenance rebuild.

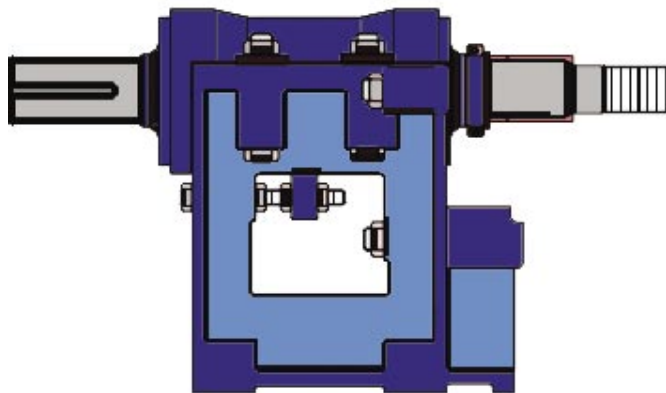

The reduction of solids grinding between the impeller and suction side reduces power consumption and wear. The millMAX™ Hybrid Suction Sealing System maintains constant flow and pressure, without increasing speed or the danger of motor overload.

